

Designed by Nature

CB - M End Profiling Machine



...brilliantly simple
simply brilliant...



...the Hoffmann Dovetail Key

CB-M

End Profiling Machine

The Hoffmann CB-M is designed to produce an exact counter-profile on the ends of glazing bars when manufacturing Georgian style windows, door manufacturing and furniture.

The two router motors have variable speed control and counter-rotation (left / right). They can be adjusted for the optimum speed to suit various wood species and profile shape and therefore produce the best possible finish. The machine is supplied without tooling, as each customer will require tooling to suit his own particular profiles. When double glazed units are fitted in windows, then these profiles are attached to the surface (plant on) with a dedicated adhesive tape.

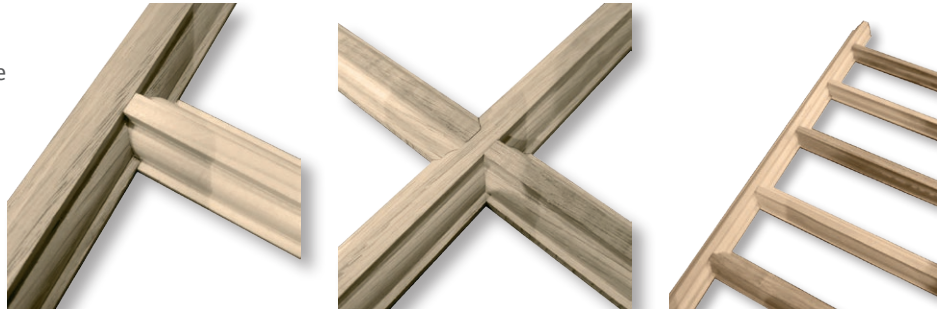
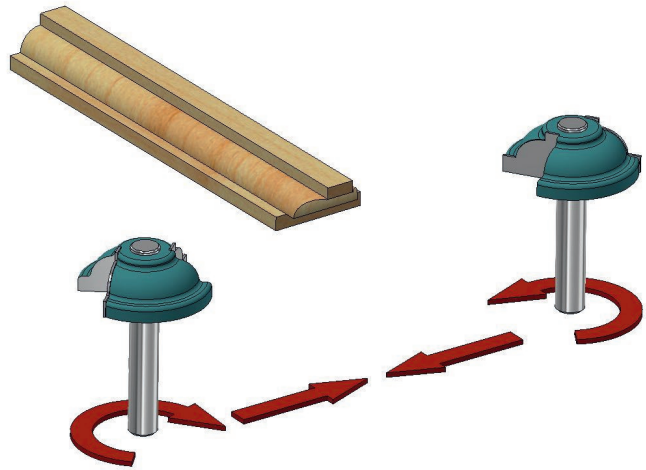

**A classic design...
manufactured
economically.**

Technical data

Power supply	1ph/N/PE 230 V 50/60Hz 2 x 2.2 kW
Motors	2 x 1050 W
Motor speed	5,000 – 24,000 rpm.
Control	manual
Work-piece clamping	pneumatic
Work-piece height.	Router bit dependant
Extraction port	Ø 75 mm
Dimensions W/D/H	36/40/50 cm
Weight	26 kg
Order No.	S1001000

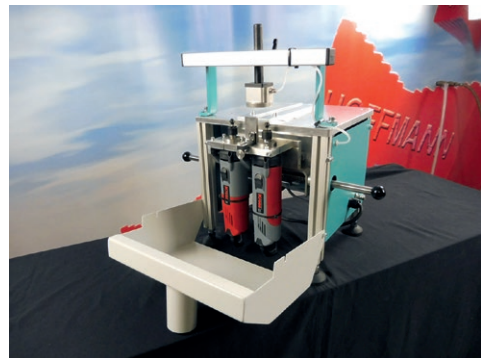

Hoffmann GmbH Maschinenbau

Mergelgrube 5 · D-76646 Bruchsal
 Telefon +49 (0) 72 51 - 95 44 0
 Telefax +49 (0) 72 51 - 95 44 44
 Home www.hoffmann-schwalbe.de
 E-Mail info@hoffmann-schwalbe.de



Were found in the
best joints...worldwide!